

THERMAL HYDROLYSIS OF WASTE ACTIVATED SLUDGE ONLY AT THE PSYTTALIA WWTP IN ATHENS: OPERATION FEEDBACKS

Zikakis D.¹, Chauzy J.², Droubogianni I.¹ and Georgakopoulos A.¹

¹Aktor S.A., Greece, ²Cambi AS, Norway

Abstract

In order to improve the energy footprint of the WWTP of Psyttalia in Athens, Greece (3,500,000 E.P), the application of Thermal Hydrolysis Process (THP) was preferred to the option of constructing additional anaerobic digestion tanks. Since August 2015 approximately half of the generated Waste Activated Sludge (WAS) has been treated by a Cambi Thermal Hydrolysis B6-4 system, in line with the contractual obligations and the intended design basis, while the thickened Primary Sludge (PS) stream is by-passing THP and is mixed with the hydrolysed WAS stream before entering the 4 digesters. The 4 other conventional digesters have treated the remaining sludge.

The dewaterability of the mixed digested sludge has significantly been improved from 20-22%DS before THP installation, up to 29-31%DS after THP installation. This is providing substantial reduction of energy use and cost savings at the digested sludge drying plant of Psyttalia. In addition, biogas generation and digester efficiency in terms of solids destruction has been increased.

Since the introduction of Thermally Hydrolysed sludge in the system, the resulting high ammonia concentration in the anaerobic digesters required the adaptation of the methanogenic pathway of digestion to the new conditions, in order for the digesters to become stable and robust. Further improvements were also necessary during the ramping up and commissioning stages in order to optimize the treatment of the viscous surplus sludge stream, so that the sludge treatment is now working properly.

Keywords

Anaerobic digestion, Drying, Energy Management, Psyttalia, Thermal Hydrolysis.

Introduction

The wastewater treatment plant of Psyttalia, is the final recipient of domestic sewage and pre-treated industrial wastewater of the greater Athens area in Greece, receiving an average wastewater flow of 730.000 m³/d, with a biological treatment capacity of 3,500,000 Equivalent Population (Figures 1 and 2). The Plant's wastewater treatment line consists of pre-treatment facilities, primary sedimentation and biological treatment. Secondary treatment is facilitated by 12 activated sludge tanks (bioreactors) with pre-anoxic denitrification for nitrogen removal. The total volume of the activate sludge bioreactor tanks is approximately 300.000 m³. Secondary clarification takes place in 64 rectangular final settling tanks (type Gould II) with an approximate effective surface of 52.000 m².

The Psyttalia WWTP was constructed in separate implementation Phases. The First (A) Phase, which was finalised in 1994, facilitated the primary treatment of the incoming wastewater loads and the stabilization of the produced Primary Sludge via four mesophilic Anaerobic Digesters (10.000m³ each). The Plant was upgraded in 2004 with the construction of the Second (B) Phase treatment facilities which incorporated additional treatment stages in order to comply with the EU Directive 91/271. Phase

B included secondary treatment, with the installation of the biological treatment stage for the wastewater line (primary effluent lift pumping station, bioreactors, final settling tanks, process water disinfection etc), and mechanical thickening for the Waste Activated Sludge as well as four additional digesters (10.000m³ each) for the stabilization of the resulting quantities of Primary Sludge (PS) and Waste Activated Sludge (WAS) and a new dewatering installation for the sludge line. Additional expansion works took place in 2007 and 2008 that include the installation of a Thermal Drying Plant for the Dewatered sludge (nominal capacity 8.625kh H₂O evap/h, for each line with four lines in total) and the construction of additional cogeneration facilities with Biogas and one with Natural Gas.

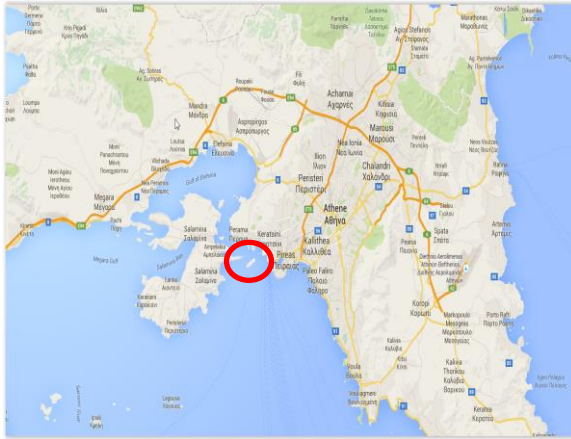

Figure 1: Location of the Psytalia WWTP



Figure 2: Aerial view of Psytalia Island with wastewater treatment work prior installation of THP

Due to that staged construction, the Plant consists of two parallel sludge treatment lines with mesophilic anaerobic digesters. Each line has four 10,000 m³ digesters that originally treated a mixture of thickened Primary Sludge (PS) and thickened Waste Activated Sludge (WAS). The PS passes through strain press fine screens and is thickened in picket fence gravity thickeners whereas WAS is thickened by gravity belt thickeners. Digested sludge is dewatered by decanter centrifuges and is finally dried at four Thermal Rotary Drum Drying lines to a concentration of >92% DS. The generated Biogas from the digestion process is used primarily as fuel (powering) for the sludge drying process and the remaining biogas is used at the cogeneration plants to produce electricity.

Process objectives and the rationale behind WAS-only THP

The main objective set in 2014 to the O&M Contractor, by the Plant Owner EYDAP, was the reduction of the overall energy consumption of the Psytalia WWTP. Focused on improving the energy footprint of the Pant, and in order to meet the contractual energy conservation target, the Contractor of the Plant AKTOR S.A., implemented a series of process modifications:

- Enhancement of volatile solids destruction and biogas generation at the Anaerobic Digestion process by WAS only Thermal Hydrolysis
- Reduction of heat energy requirement at the Drying Plant, by reducing the volume of water that needs to be evaporated, due to the increased sludge dewaterability from the application of the THP
- Recovery of heat energy from various sources of the WWTP and the integration of the heating water network. Wasted heat from the coolers of the biological treatment blowers and the CHP exhaust gas streams were recovered and utilized for digestion heating
- Steam generation from heat energy recovery of the CHP exhaust stream

- Installation of a hydroelectric power generator at the effluent of the WWTP
- Installation of an integrated power management, monitoring and auditing system
- Replacement of key equipment with new for process optimization and energy conservation

Integral Part of that energy conservation incentive was the application of Thermal Hydrolysis for treating approximately half of the generated Waste Activated Sludge stream of the Psyttalia WWTP. Alternative plans to implementing Thermal Hydrolysis at Psyttalia WWTP included the enhancement of the conventional operating scheme by the construction of two additional mesophilic anaerobic digesters.

This WAS-Only configuration is used on other plants, for instance at Long Reach UK (Shana 2013) and Hengelo NL (Oosterhuis 2014). The process is similar to the already established THP sludge pre-treatment for anaerobic digestion but involves only the thermal hydrolysis of the thickened WAS stream. Thickened Primary sludge is then mixed directly with the hydrolysed sludge prior to entering digestion. As opposed to traditional THP configurations, the selection of the WAS only treatment scheme leads to a lower capital and operational cost investment, which include the selection and installation of a smaller THP plant, smaller pre-dewatering and steam generation plants, reduced demand for steam generation and reduced polymer consumption. Additionally, the thickened PS sludge stream now acts as a cooling medium for the digester feeding stream and hence smaller cooling equipment can be selected (or even no equipment at all).

Main disadvantages, as opposed to the full treatment of the mixed sludge in the THP, include the reduction of the anticipated performance benefits of the anaerobic digesters, the reduction of the volumetric VS load to the digestion and the inability to produce a final cake that is pathogen free. However, in the plants where the end use of the dewatered cake is not for agriculture and rely on either drying or incineration, the later disadvantage is not relevant. For WWTP plants such as Psyttalia where the dewatered cake is finally dried and shipped off for incineration at cement kilns, the benefit of the WAS only option, and especially the high level of dewaterability of the digested sludge, is significant. Higher dewaterability means reduced evaporation capacity requirement at the Drying Plant which translates directly into fuel reduction. By accounting the fact that digested primary sludge can already be dewatered to a higher degree than digested WAS, or a mixture of digested PS and WAS (Metcalf and Eddy, fourth edition Table 14-42), the dewaterability of the THP WAS-only digested mixture can be comparable to that of the fully hydrolysed digested mixture.

At the time of planning, and before the installation of the THP, anticipated performance figures included the increase of dewatered sludge concentration from 22% to at least 28% for final dewatered cake dry solids, an increase to biogas generation by 15% and VS reduction increase from the already measured values of 45-46% for conventional digestion, in the range of to over 52%. These figures were supported by bench pilot experiments and analyses made specifically for Psyttalia WWTP by Thames Water in cooperation with CAMBI, where thickened PS and WAS samples were collected and sent regularly for feeding a small-scale pilot THP rig and an array of Chemostat digesters. In addition, Dewaterability potential analysis was conducted by KBKopp laboratories.

A first train of THP, a Cambi Thermal Hydrolysis B6-4 system (figure 3), has been installed in 2015 as pre-treatment of the 4 (B) Phase digesters over the 8 existing digesters (10,000 m³ each) (figure 4), the other 4 (A) Phase digesters being still used as conventional mesophilic digesters. Additional auxiliary units included the installation of two pre-dewatering decanters, which receive part of the thickened WAS from the gravity belt thickeners and dewater the sludge stream before being treated to the THP. The steam required for the operation of the THP is produced at a new hybrid steam generator that utilizes primarily the recovered heat energy from the CHP exhaust gas stream.



Figure 3: B6-4 thermal hydrolysis plant with 4 reactors at Psyttalia WWTP



Figure 4: Aerial view of the THP plant (Bottom) and 8 mesophilic anaerobic digesters at Psyttalia WWTP

The design basis for the WAS-only THP treatment line B (Phase) included the installation of a Cambi Thermal Hydrolysis B6-4 system for treating 42,5 tons of pre-dewatered WAS sludge (12% to 16,5% in DS concentration). The loading ratio between the Hydrolysed WAS stream (kg DS) and the thickened PS stream (kg DS), at the inlet of the anaerobic digesters, was 40 % and 60% respectively. The total design load for the four THP digesters is 106 tons DS/d of sludge with an Organic Loading Rate (OLR) of approximately 2,1 kgVS/m³.d. The remaining amounts of thickened WAS and PS sludge (of approximately the same quantity) are fed to the four conventional mesophilic anaerobic digesters (CMAD) of the parallel A (Phase) sludge line. The six dewatering decanters were separated into two groups, with each group receiving the digested sludge amounts of the two respective lines.

A new dewatering decanter was also replaced with a new GEA Westphalia CF7000 Separator for process optimization. The design steam requirement for operating the THP plant is approximately 2,2 m³ H₂O /h (for WAS concentration of 16,5% DS at the inlet of the THP). The current wastewater and

sludge treatment schemes of the Psyttalia WWTP, after the integration of the THP unit with the B Phase sludge treatment line, can be summarized in figure 5.

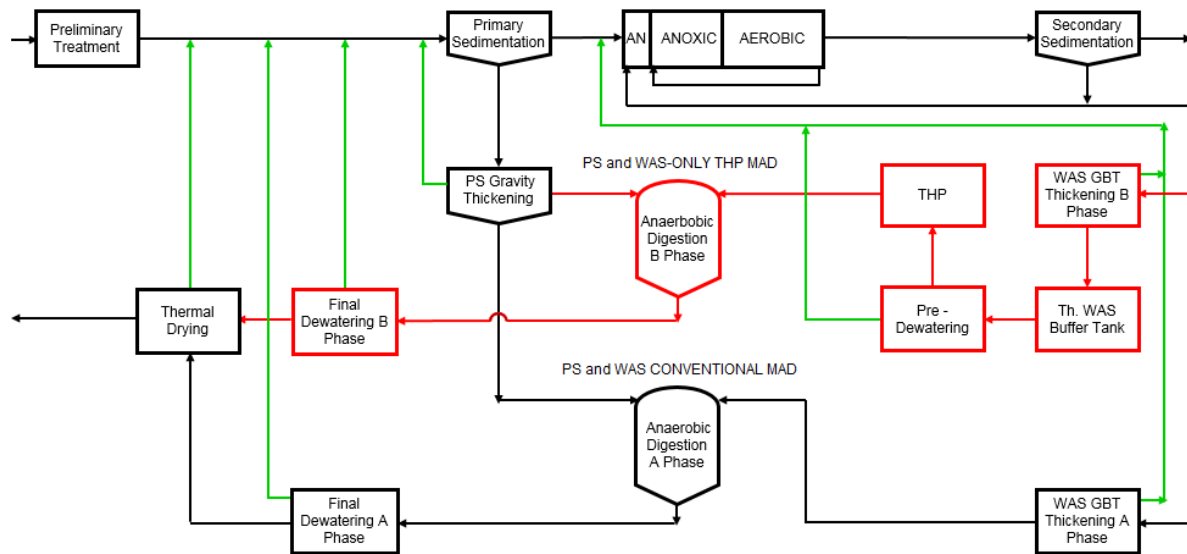

Figure 5: Simplified flow diagram of the Wastewater and Sludge treatment lines of Psyttalia WWTP. The WAS-Only treatment sludge line is highlighted in red.

Operational performances

Anticipated performance figures included the increase of Volatile Solids Removal in the range of over 52%, an increase of biogas generation by 15% and dewatered sludge concentration increase from 22% to at least 28% for final dewatered cake dry solids. Process performance for anaerobic digestion is assessed for the period from May 2016 after the introduction of hydrolysed WAS in the system, when normal operation was assumed with design OLR values, until March 2017. The findings are compared with the process performance figures of the period August 2014 to June 2015, before the operation of the THP. That specific period was selected as being more representative, because just before August 2014 the "B Phase" digesters were evacuated in series and been cleaned of debris and accumulated grit as part of a scheduled maintenance plan.

Volatile Solids reduction

Figure 6 depicts the calculated VS reduction percentages (Van Kleeck, moving average) for the respective periods of August 2014 until June 2015 just before the operation of the THP and May 2016 to March 2017 after the introduction of hydrolysed WAS. Average OLR of the former period was in the order of 2,07 kgVS/m³ similar to the design loading value of the THP process scheme. It should be noted that the WAS-Only OLR applied at Psyttalia is quite low and could be higher, as the intention at Psyttalia was not to increase the digestion capacity but to decrease the WWTP power consumption. The average VS reduction for the former period was in the range 45% whereas the calculated percentage for the period after the operation of the THP, varied from around 45% during the first months of stable operation, to over 60% in the later months.

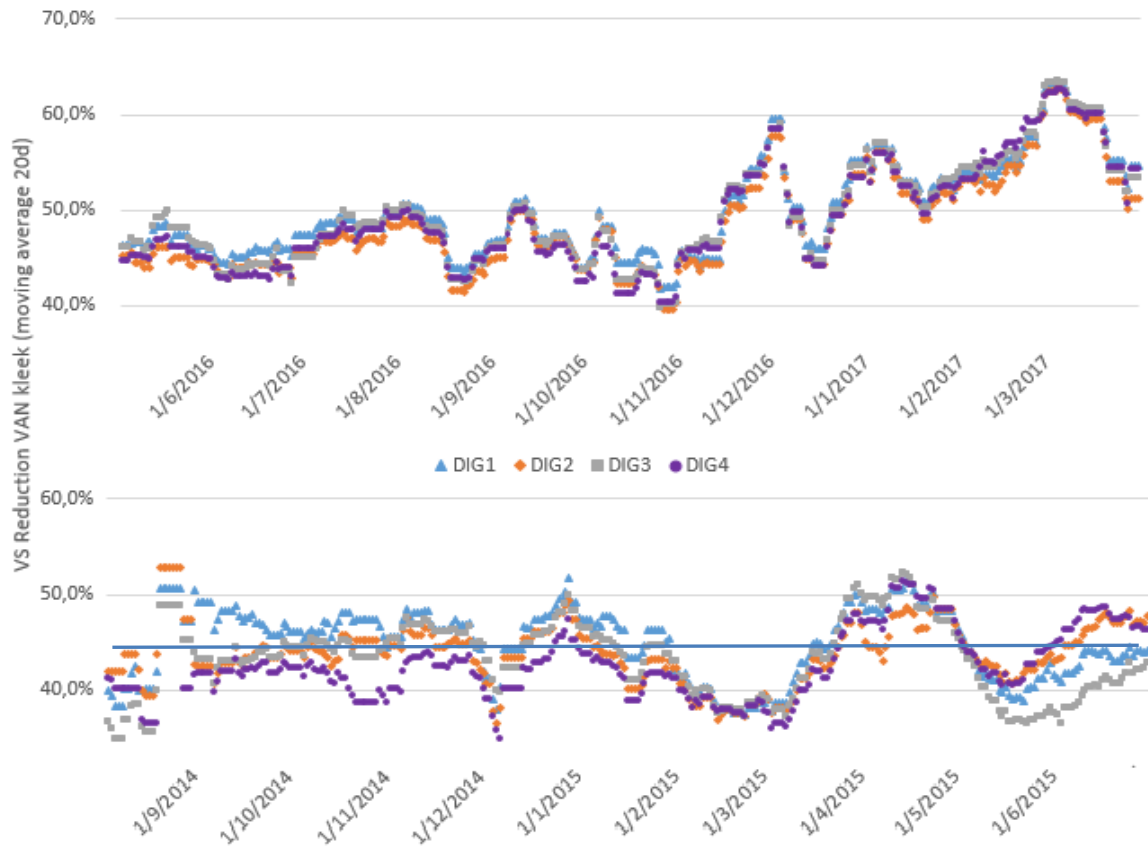

Figure 6: Calculated VS Reduction (Van Kleeck) for periods before (8/2014-7/2015) and after (5/2016-3/2017) the operation of the WAS-Only THP

It should be noted however that the amount of hydrolysed WAS varied significantly during the operating months (May 2016 – March 2107), primarily due to a design limitation that involved the temperature regulation of the anaerobic digesters feeding stream. The design configuration of the THP sludge treatment line of Psyttalia WWTP did not include a cooling system for the hydrolysed WAS stream, as wastewater temperature was expected to be lower. Instead, the non-hydrolysed thickened Primary Sludge stream acts as the cooling medium when mixed with the hydrolysed WAS stream before entering digestion. As a result, the measured temperature at the digester feeding stream became the deciding factor in selecting the appropriate ratio between hydrolysed WAS and thickened PS flows and by extension loads at the feed. This limitation became more evident during the warmer months when the elevated primary sludge temperatures required increased amounts to be mixed at the feeding stream, at the expense of the hydrolysed WAS stream. Figure 7 depicts the variation of the DS load ratio of hydrolysed WAS to total DS load at digester feed in respect to the monthly average temperature values of the thickened primary sludge stream.

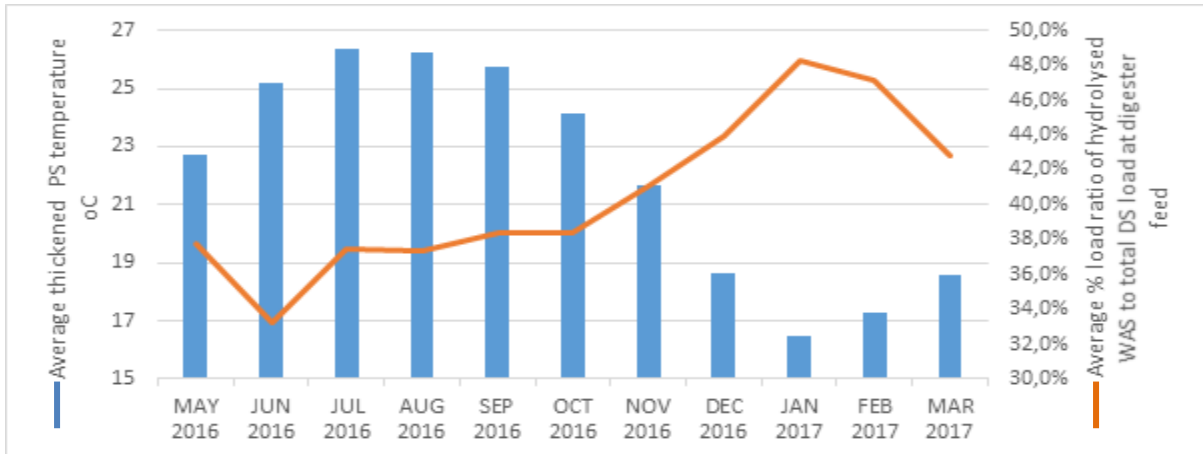

Figure 7: DS load ratio of hydrolysed WAS to total DS load at digester feed and thickened PS stream temperature

The need to maintain and respect the design OLR of the THP digesters, the limited availability of PS especially during the summer months and the necessity to support appropriate loading rates at the remaining four conventional MAD digesters of the A Phase led to a varied hydrolysed WAS/ Total feed loading ratio. If that monthly variation is projected with the calculated monthly average VS reduction values, (figures 8, 9) the increased VS reduction percentages of the later months is probably related to the increased load percentage of hydrolysed WAS (HWAS) introduced in the digesters (or either attributed to the gradual adaptation of the digestion process).

It should also be noted that higher percentages of Hydrolysed WAS (HWAS) loads, for given OLRs, also signify higher retention times in digestion as HWAS streams have higher DS concentrations than thickened PS streams. The design ratio value of 40% WAS to 60% PS was satisfied after November 2016 with corresponding VS reduction values close to 52 %.

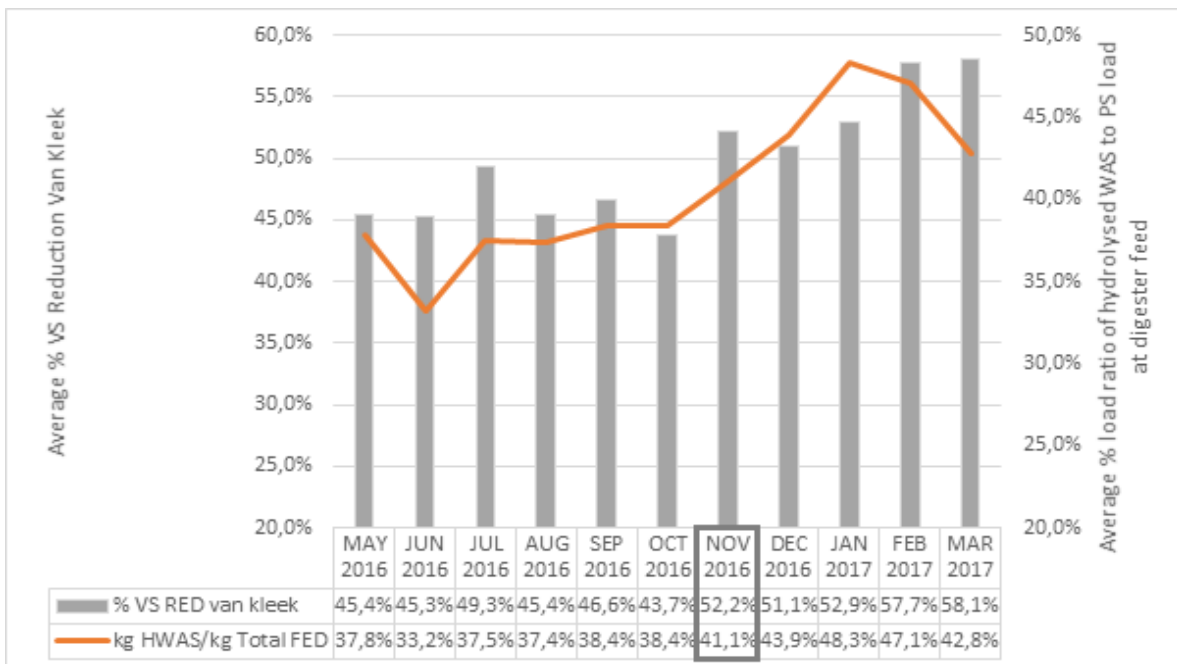

Figure 8: DS load ratio of hydrolysed WAS to total DS load at digester feed and calculated VS reduction

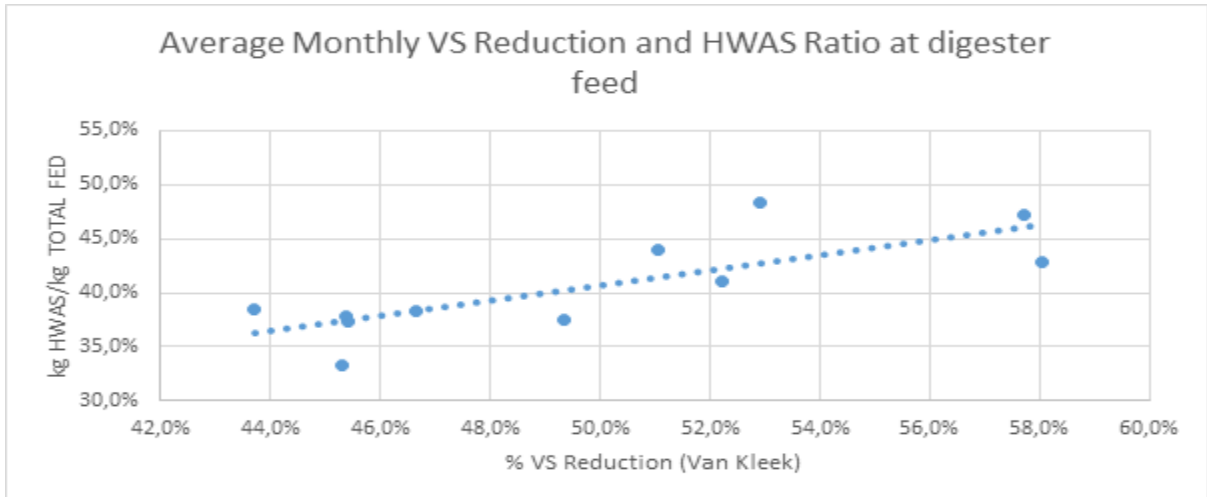

Figure 9: Relationship of the DS load ratio of hydrolysed WAS to total DS load at digester feed and calculated VS reduction

Biogas Production

Figure 10 depicts the daily average specific biogas production values in terms of Nm³/kg TS fed for the four B Phase digesters for a period of over two years. Several days have been omitted, that correspond to the four months during digester Conditioning (February 2016 – April 2106) and to the early disturbances of October 2015.

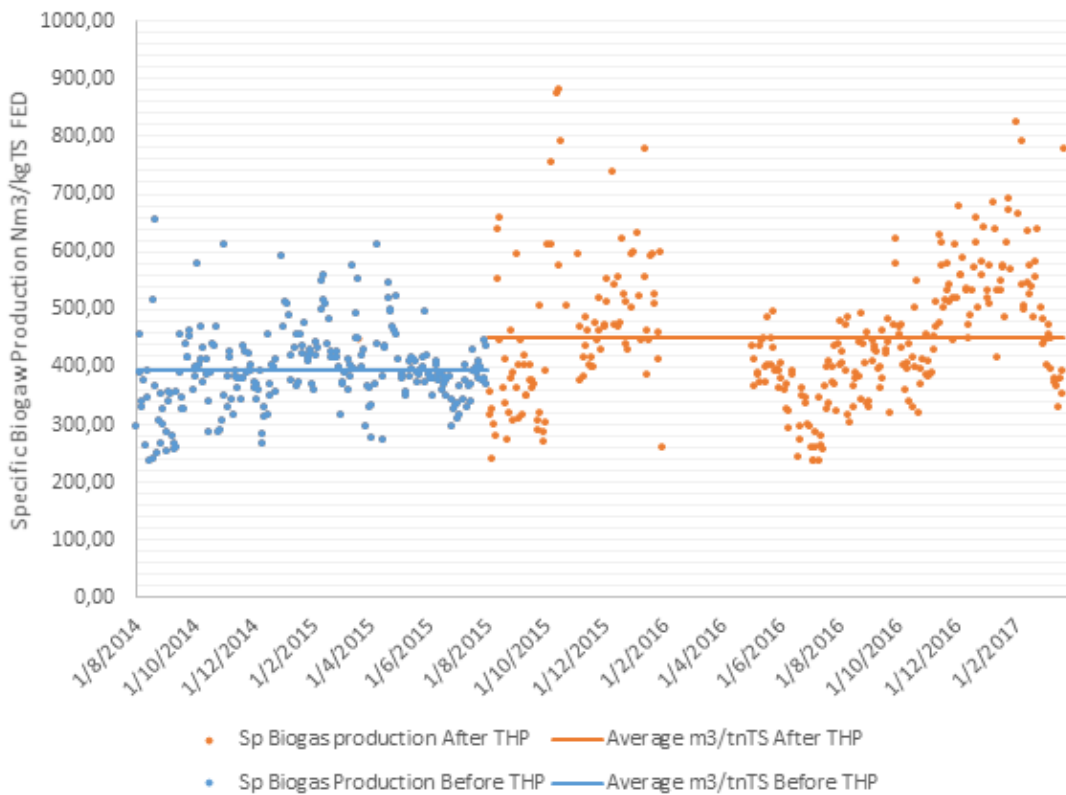

Figure 10: Calculated Specific Biogas Production in Nm³/tonDS fed for periods before (8/2014-7/2015) and after (8/2016-3/2017) the operation of the WAS-Only THP.

The average value of specific biogas production for the yearly period of August 2014 to July 2014, before the installation and operation of the THP plant, is calculated as 393 Nm³ / kg TS fed. After the introduction of hydrolysed WAS in the system the specific biogas value saw a significant increase especially after November 2015. The corresponding average value for the latter period, after the introduction of hydrolysed WAS in digestion, was 452 Nm³ / kg TS, which is approximately a 15% increase, close to the expected value.

For the latter months of stable operation, from May 2016 to March 2017, the specific biogas production values follow closely the volatile solids (VS) reduction increase. After November 2016 when the VS reduction values increased to over the target value of 52%, specific biogas production daily values were frequently calculated to be over 500 Nm³ / kg TS.

Dewaterability

After the operation of the THP in August of 2015 and the introduction of hydrolysed WAS in the four “B Phase” digesters, the sludge treatment process was separated into two distinct lines. Three of the final dewatering decanters (6 in total) received the mixed digested sludge from the conventional digestion treatment line (CMAD), and the remaining three decanters, including a newly installed GEA Westphalia CF7000 separator, received the mixed digested sludge from the THP WAS-only treatment line (HWAS MAD).

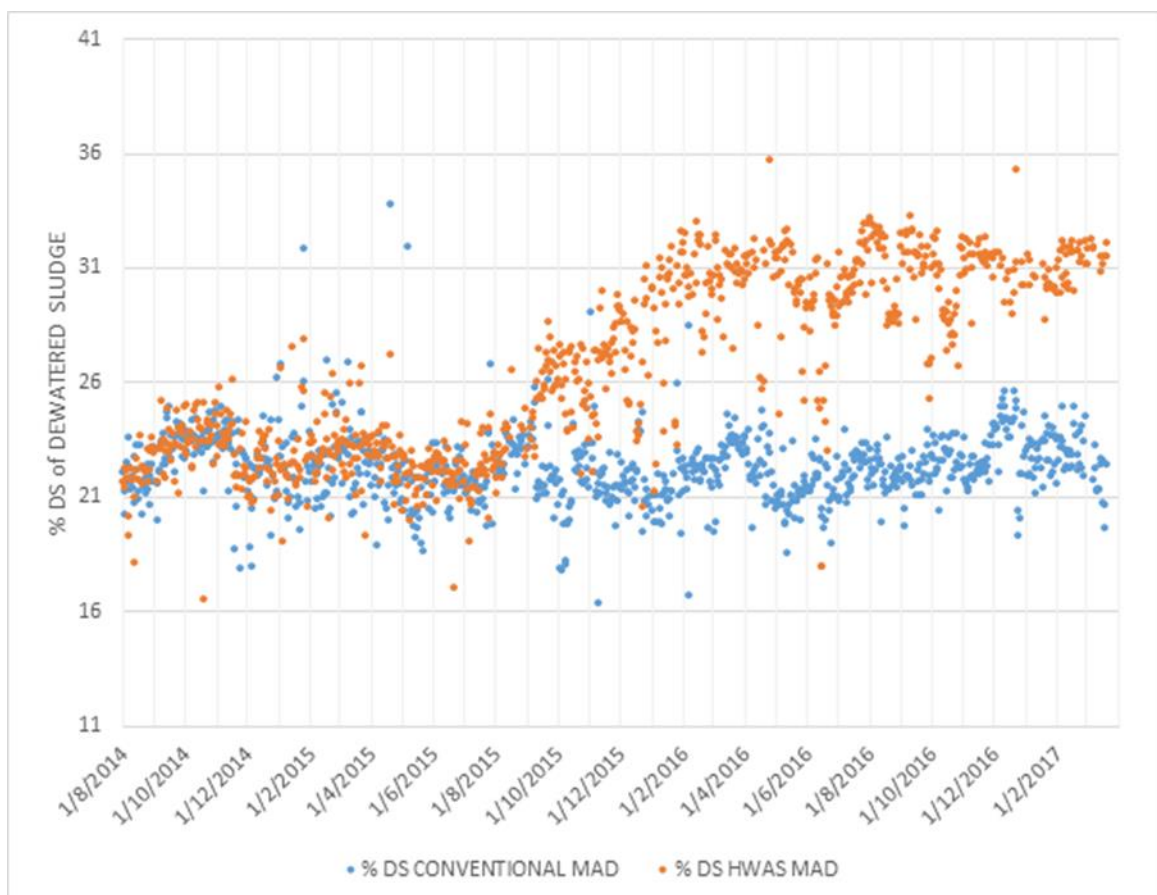

Figure 11: Dryness in %DS of dewatered digested sludge, for Phase A (conventional) and Phase B (THP) digesters

Figure 11 presents the daily measured %TS concentrations of dewatered sludge grab samples, depicted separately for the two different process lines. For the period before the operation of the THP,

(August 2014 until July 2015), there was no separation between the two treatment lines, as the digested sludge from all eight digesters of the WWTP was mixed prior to dewatering.

After the separation of the two process lines in August 2015, the dewatered sludge concentration of the THP treatment line saw a gradual %DS concentration increase. The dewatered sludge concentration of the THP digested sludge (mixed hydrolysed WAS and PS digested sludge) was stabilized on February 2016 to approximately 31%DS whereas the dewatered sludge from the conventional treatment line remained constant and close to the average value of 22%DS. It is also evident that the varied degree of volatile solids destruction throughout the operating months, as described above for digester performance, didn't seem to affect the dewaterability performance of the produced sludge, as the later remained fairly constant after February 2016.

Conclusion

The WAS-Only treatment scheme of Psyttalia WWTP involves the treatment of 50% of the generated WAS loads. The four dedicated digesters of the THP WAS-only line receive approximately half of the generated sludge quantities of the WWTP, a mixture of thermally Hydrolysed WAS and non-hydrolysed thickened PS.

The exclusive treatment of the WAS stream at the THP, prolonged the initial ramping up period as the handling and pumping of the viscous sludge stream required mechanical modifications at the feeding configuration of the THP, especially when operating with high DS% concentrations at the inlet.

Following a process adaptation period due to the increasing ammonium concentrations in the digesters, as a post-effect of the enhanced hydrolysis and the higher DS concentration at the feed, and since the successful completion of the commissioning period, the THP plant has operated stably for nearly a year. The following key performance indicators, as measured and calculated during the period of operation (May 2016 – March 2017) summarize the benefits of the WAS-Only configuration:

- Improved dewaterability from 22% dry solids to 31% (minimum target value of 28%),
- Increased Volatile Solids reduction from 45% to over 52% (minimum target value of 52%),
- Increased biogas production from approximately 390 Nm³ / kg TS fed to 450 Nm³ / kg TS fed, 15,4% increase (minimum target value of 15%).

For the Psyttalia WWTP, of particular significance was the increased sludge dewaterability effect as an immediate consequence from the application of the THP. The reduced volume of water at the inlet of the drying plant means that less heat energy is necessary for drying operation. For the drying plant, with a target value of 92% DS at the outlet, the increase of the fed dewatered sludge concentration, from 22% DS dry solids to 31% DS, translates directly into a 38,2% heat reduction requirement. For the Psyttalia WWTP where only half of the generated sludge is being treated to the digesters and decanters of the WAS-Only line, the overall evaporation requirement at the drying plant is reduced by approximately 86 tons of water per day or in effect by 19,1% in overall heat energy consumption and biogas consumption needs.

If projected to the overall biogas production values at Psyttalia WWTP (for both sludge treatment lines), the reduction of consumed biogas at the drying plant means approximately that 16% of the daily generated amount is now available for other uses. By adding another 7.7% from the biogas production increase at the anaerobic digesters (by considering the biogas increase of 15,4% from the WAS-only treatment line digesters, which receive half of the sludge amounts) the total available biogas is now increased by nearly 24%.

Essentially, by treating approximately only 20% of the generated sludge amounts at the THP (WAS-only THP for half of the total WAS amount and with a 40% to 60% WAS and PS respective load ratios), approximately 24% more biogas is now available that may be used at the CHP plant to generate electricity.

More research and observations are to follow in order to further extent our assessment of the WAS-Only THP application at Psyttalia. Digester operation is monitored closely on a daily basis in order to identify and understand more accurately the boundaries of the system. Process performance and benefits from the THP treatment are recorded and calculated in order to optimize the operation.

Future plans for the Psyttalia WWTP include the installation of a cooler at the outlet of the THP plant in order to eliminate a substantial limitation in selecting appropriate feeding ratios for the Digesters. Plant expansion is also considered, by proposing the plant Owner to invest further in THP technology. Energy reduction benefits are expected to double by treating all of the generated WAS amounts, with the installation of another train of WAS-Only Thermal Hydrolysis.

References

Metcalf and Eddy, *Wastewater engineering, treatment and reuse, fourth edition*. Table 14-2.

Oosterhuis, M., Ringoot, D., Hendriks, A. and Roeleveld, P (2014). Thermal hydrolysis of waste activated sludge at Hengelo Wastewater Treatment Plant, The Netherlands. *Water Science & Technology* 70.1

Shana, A., Fountain, P., Mills, N. and Hunt, P. (2013) SAS Only THP with series digestion – More options for energy recovery. *Proceedings of the 18th Biosolids & Organic Resources Conference*, Manchester.